

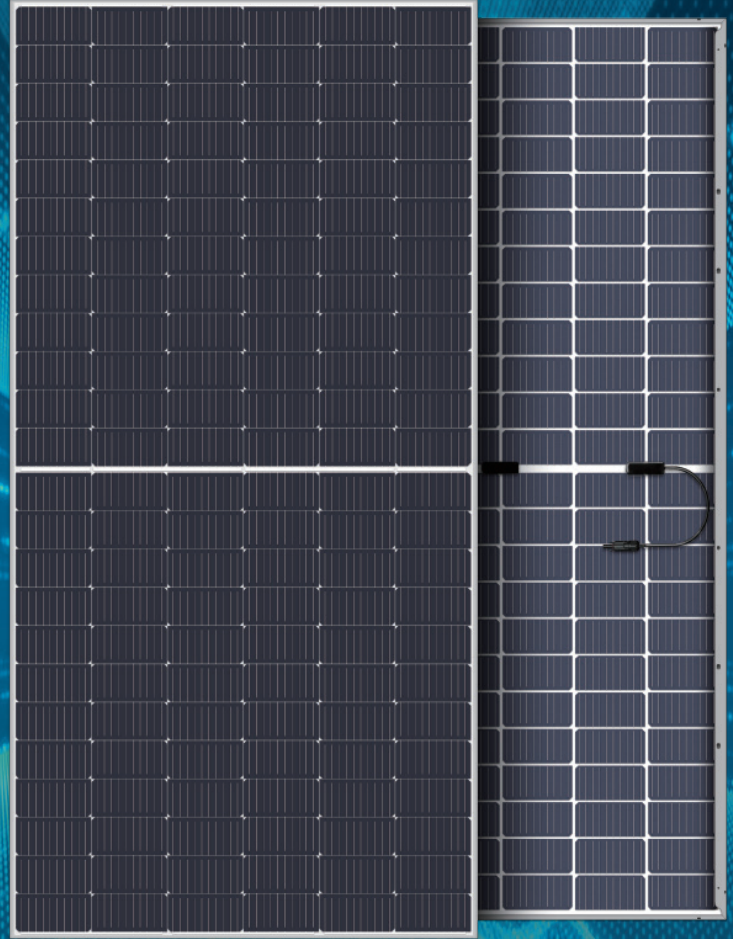

540-560W

SK9612M(HV)C-U

MONO 10BB Half-Cut Bifacial Module



Half-Cut technique leads to increased power output

Compared with the whole cell, the current of half cell is halved, the heat loss is reduced, the hot spot temperature is reduced, and the power can be effectively increased.



Series-parallel wiring mode results in reduced shading loss

Series-parallel wiring will not only reduce power loss from shade but also improves the effective use of supports and space.



Excellent temperature performance

The temperature of HC module is 1.6 °C lower than that of the conventional module under the same working condition, which results less power loss.



Reduced encapsulation loss due to reduced current

HC module is of lower current and lower CTM loss at around 0.2%.

LINEAR PERFORMANCE WARRANTY

15 years

Product warranty on materials and workmanship

30 years

Linear power output warranty

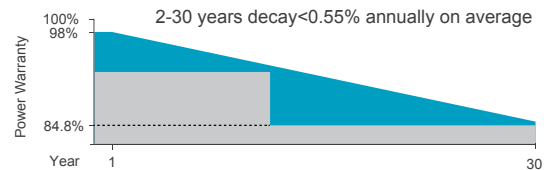

CERTIFICATES

ISO 9001: 2015
Quality Management System

IEC 61215 / IEC 61730 / UL 61730

ISO 14001: 2015
Environmental Management System

ISO 45001 : 2018
Occupational Health & Safety Management System

*Certification requirements vary in different markets, please consult with Akcome USA sales team for appropriate certification.



540-560W

MONO 10BB Half-Cut Module



ELECTRICAL PARAMETERS @ STC

Max. Power Output Pmax (W)	540	545	550	555
Power Tolerance	0~+3%	41.76	41.95	42.14
Max. Power Voltage Vmp (V)	41.57	13.06	13.12	13.18
Max. Power Current Imp (A)	13.00	50.21	50.41	50.59
Open Circuit Voltage Voc (V)	50.02	14.09	14.17	14.24
Short Circuit Current Isc (A)	14.02	41.76	41.95	42.14
Module Efficiency (%)	20.90	21.10	21.30	21.49

*STC (Standard Test Condition): Irradiance 1000W/m², Cell Temperature 25°C, Air Mass 1.5
 *Measurement Tolerance (±3.0%)

ELECTRICAL PARAMETERS @ NOCT

Max. Power Output Pmax (W)	408	412	416	420
Max. Power Voltage Vmp (V)	38.45	38.64	38.81	38.96
Max. Power Current Imp (A)	10.61	10.67	10.73	10.79
Open Circuit Voltage Voc (V)	47.36	47.55	47.74	47.93
Short Circuit Current Isc (A)	11.41	11.48	11.56	11.63

*NOCT(Nominal Operating Cell Temperature): Irradiance 800 W/m², Ambient Temperature 20 °C, Wind Speed 1m/s

TEMPERATURE COEFFICIENTS

Temperature Coefficients of Pmp	-0.35%/°C
Temperature Coefficients of Voc	-0.27%/°C
Temperature Coefficients of Isc	+0.045%/°C

MECHANICAL PARAMETERS

Cell Type	Mono 182x91mm
Number of Cells	144pcs(6x24)
Dimensions (L*W*H)	2278x1134x35mm
Weight	28.5kg
Frame	Anodised Aluminum
Junction Box	IP68, 3 bypass diodes
Cable, Length	4.0mm ² , 300mm

OPERATING CONDITION

Maximum System Voltage(V)	1500(DC)
Operating Temperature(°C)	-40~+85
Max. Wind Load / Snow Load(Pa)	2400/5400
Max. Series Fuse Rating(A)	25
Fire Rating	Class C
NOCT	41±2°C

PACKAGE INFORMATION

Container 40'HQ	620pcs
Quantity / Pallet	31pcs
Package size: 2310×1115×1249mm; Net weight: 883.5kg; Gross weight: 940.5kg	

ASSEMBLY DRAWING (Unit:mm)

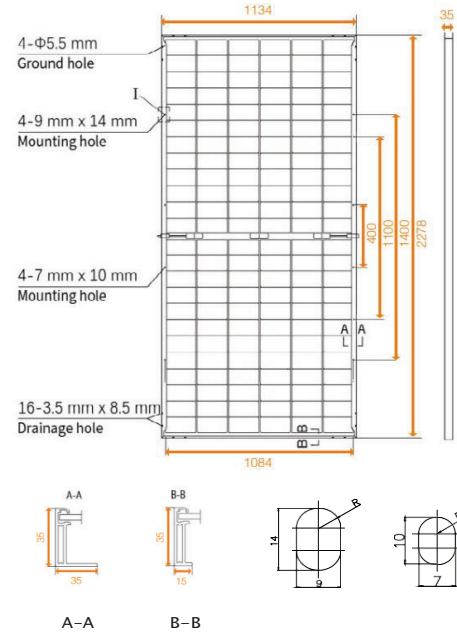

I-V CURVES

